



110 T Aluminum Foil Container Production Line



OMID KALAI E KEIHAN Co.,Ltd

www.omidkala.com



The production line include the following equipments:

Feeding Machine With Lubricated Oil System + 110 T Press Machine + Auto-Stacker + Scrap Collector

Features:

The machine adopts programmable logic controller (PLC) as the controlling system, it's reliable. The feeding length, producing speed and other parameter are easily set, this integration of Gas& Electrical centralized control, automated production.

The feeding is controlled by stepper system, the feeding length is accurate And can be adjusted freely from 20m to 999m.

The accurate press adopts steel plates joining body, variable frequency speed regulation, dry type friction clutch-on-off, rigid over-load protector to protect the press. In short, this is a high accuracy and reliability press.

1. Feeding Machine With Lubricated Oil System:

- 1) Max. material roll diameter: \varnothing 800mm
- 2) Max. material roll width: 1200mm
- 3) Feeding speed: 20-50M/min
- 4) Feeding length: 30-999mm
- 5) Feeding tolerance: +/-0.3mm
- 6) Capacity: 3Kw
- 7) Voltage: 380V/220V
- 8) Net weight: 1200kg
- 9) Dimension: 2270x1250x800mm (L*W*H)

2. Stacker

- 1) Conveyor width: 550mm
- 2) Collector belt height: 920 +/-25mm
- 3) Min size of container: 100 x100mm (size can be adjusted)
- 4) Max size of container: 500x300mm
- 5) Max stacking height: 420mm
- 6) Capacity: 3kw
- 7) Net weight: 1000kgs
- 8) : 2800 x 780 x 1500mm(L*W*H)

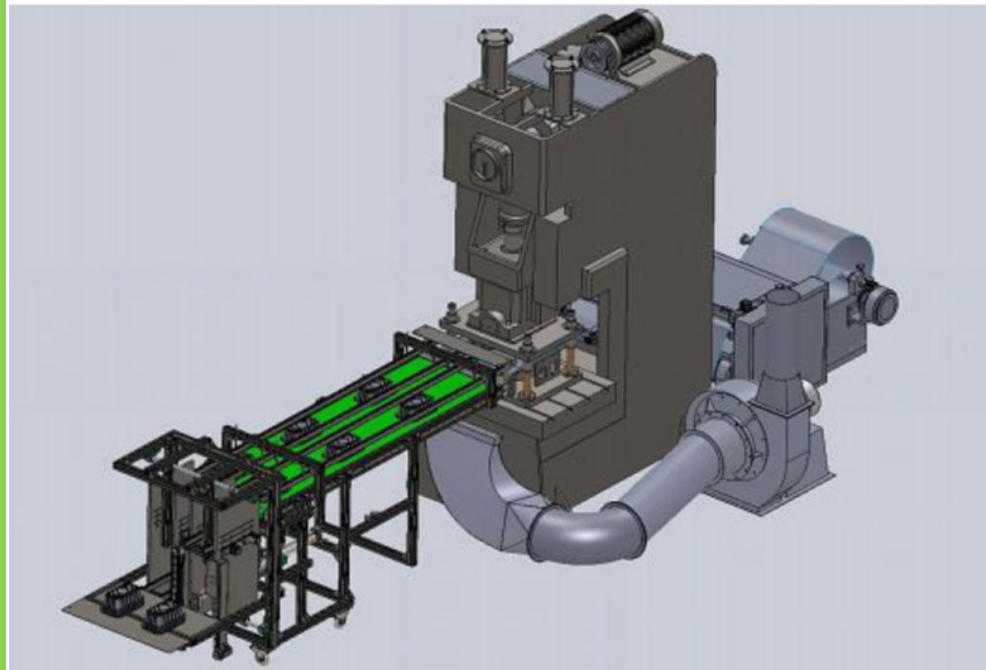

3. 110 T High Accuracy

Pneumatic Press Machine:

- 1) Pressure: 1100KN
- 2) Body work plate hole dimension: 300*300mm
- 3) Stroke time: 70-100times/min
- 4) Stroke height: 340-500mm
- 5) Work plate thickness: 100mm
- 6) Max. die installation height: 490mm
- 7) Dimension of slide block bottom, size of handle hole:480*400mm
- 8) The distance from the center of slice to the body: 340mm
- 9) The height adjustment for die: 80mm
- 10) Die handle hole dimension: 60mm
- 11) Work plate dimension: 1480*1000 mm
- 12) Dimension: 2150*1800*3600mm (L*W*H)
- 13) Motor capacity: 15 KW
- 14) Net weight: 15500kg
- 15) Voltage:3-380v 50Hz 4 /4wires

4. Scrap Collector

- 1) Rotate speed: 1450rpm
- 2) Capacity: 4kw
- 3) lift:1.5m

5. Mould:



The mould price depends on your container size.

Note:

1) Semi-automatic 110 T production line(including 1 unit feeding machine,1 unit 110 T press machine and 1 unit collect desk) : FOB shanghai

2) Full-automatic 110 T production line(including 1 unit feeding machine,1 unit 110 T press machine and 1 unit automatic stacker and 1 unit scrap collector) : FOB shanghai

Delivery time: 30days



The Feeding Machine With Lubricated Oil System



The 110 T Press Machine



The Automatic Stacker



The Scrap Collector

OMID KALAIE KEIHAN.,Co Ltd

Unit 3, No 7 ,10th Alley,Mofatteh St,
Beheshti Ave, Tehran— IRAN

Ph : +98-21-88535593
Fax : +98-21-88753350
Email : info@omidkala.com

www.omidkala.com.